

Charisma™ LED Double Sided Light Box without Lights - XSD Series

First start by assembling corners. There are three (3) brackets per corner. All extrusion sections are numbered to identify which pieces go together, 1 with 1, 2 with 2, etc.

1. Insert the bent bracket into the same extrusion section. Firmly screw the bracket into place. Take the mating extrusion piece with matching number. Guide the corner brackets in, then tighten all brackets.
2. Repeat assembly steps for the three remaining corners.
3. To install the graphic, take the corner with the pull tag on it and press about 6"-10" of silicone into the frame channel. Repeat for the opposite corner. Repeat for the next corner. Lastly, repeat for the final corner.
4. After all corners are pressed in, press the silicone into the frame channel at the mid-points on all four sides.
5. Press silicone into frame evenly between the corner and midpoints.
6. To remove the graphic from the frame, simply pull up on the pull tag.

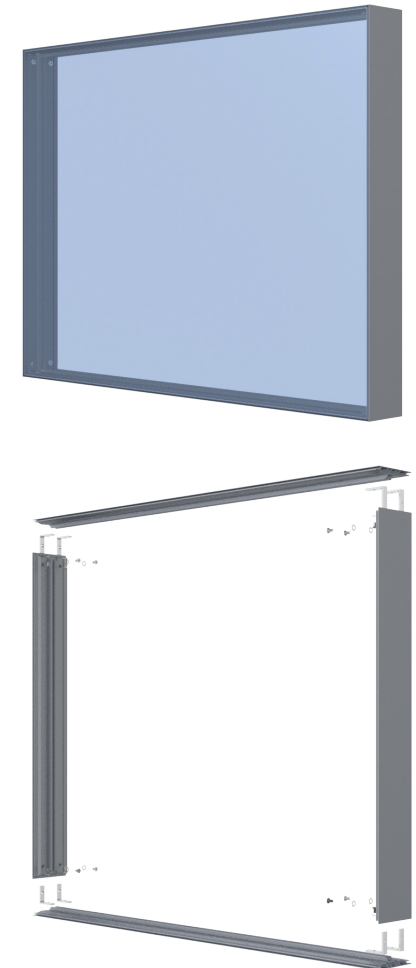
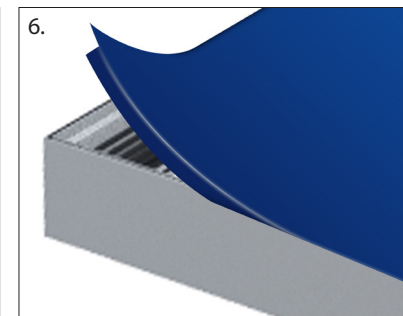
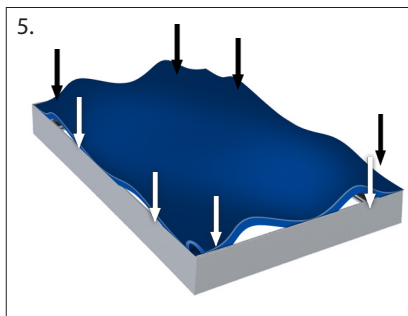
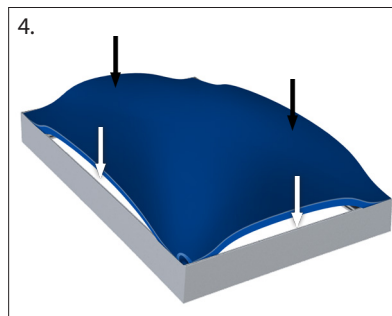
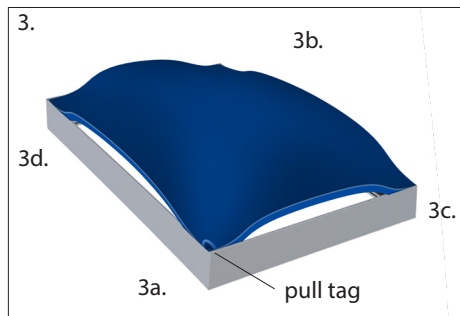
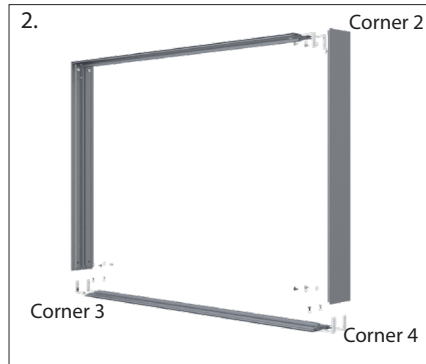
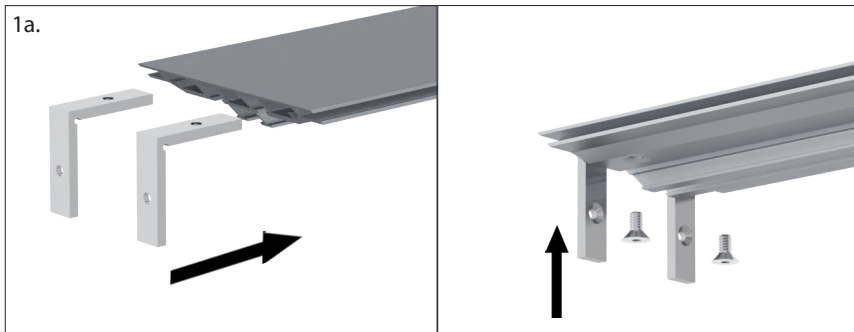

XSD34 shown